

EZ-TRAP

Wiring instructions for installing the following Aspen Pumps into
DAIKIN (230V) minisplits:

Models FTXS09,12,15,18,24 DVJU, CTX09DVJU (RA Series)

Mini Orange Mini Lime Mini Aqua
Maxi Orange Maxi Lime

1. Check voltage at evaporator and ensure that pump voltage is correct.
2. Install 1 amp inline fuse between evaporator and pump to protect pump and unit.
3. Connect pump power cable to terminal block in evaporator as shown in diagram. This will ensure that pump is powered only when evaporator has power.

NOTE :

DO NOT USE SEPARATE 230 VOLT OUTLET TO POWER PUMP AS THIS IS NOT FAIL SAFE AND MAY CAUSE AN OVERFLOW!

4. Disconnect wire which goes from Terminal L2 to PCB. Connect grey wire from pump to Terminal L2. Connect wire removed from Terminal L2 to purple wire from pump with a wire nut. Do not use orange wire, tape end to isolate.

NOTE :

ALARM WIRE MUST BE CONNECTED TO ENSURE THAT, IN CASE OF PUMP FAILURE OR BLOCKAGE IN DISCHARGE HOSE, EVAPORATOR WILL SHUT DOWN.

CONNECTION OF THE OVERFLOW ALARM CIRCUIT IS MANDATORY AND FAILURE TO DO SO WILL INVALIDATE PUMP WARRANTY!

Mini Orange
Mini Lime
Mini Aqua

230V AC

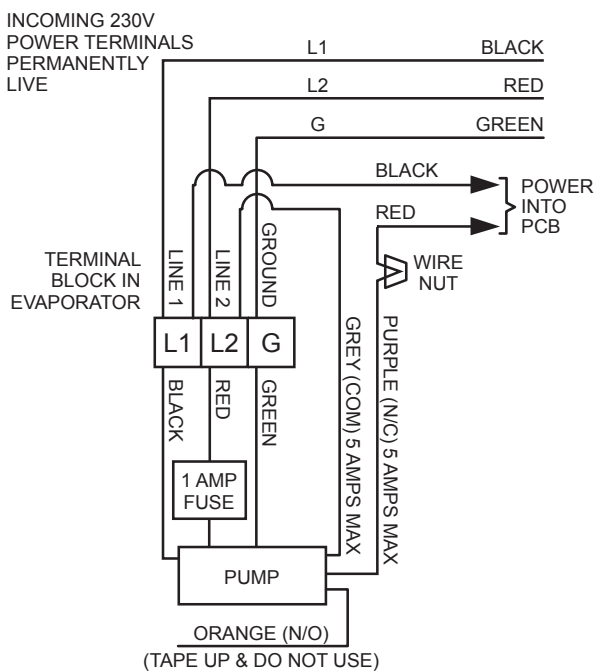

Maxi Orange
Maxi Lime

230V AC

