

EZ-TRAP

Wiring instructions for installing the following Aspen Pumps into

FRIEDRICH 115V MODELS:

M09CF, M12CF, M09YF, M12YF

Mini Orange

Mini Lime

Mini Aqua

Maxi Orange

Maxi Lime

1. Check voltage at evaporator and ensure that pump voltage is correct.
2. Install 1 amp inline fuse between evaporator and pump to protect pump and unit.
3. Connect pump power cable to terminal block in evaporator as shown on diagram. This will ensure that pump is powered only when evaporator has power.

NOTE :

DO NOT USE SEPARATE 115 VOLT OUTLET TO POWER PUMP AS THIS IS NOT FAIL SAFE AND MAY CAUSE AN OVERFLOW!

4. Break wire 3 and re-connect as shown in diagram using gray and purple wires only. Do not use orange wire, tape end to isolate.

NOTE :

OVERFLOW ALARM WIRE MUST BE CONNECTED TO ENSURE THAT, IN CASE OF PUMP FAILURE OR BLOCKAGE IN DISCHARGE HOSE, EVAPORATOR WILL SHUT DOWN.

CONNECTION OF THE OVERFLOW ALARM CIRCUIT IS MANDATORY AND FAILURE TO DO SO WILL INVALIDATE PUMP WARRANTY!

**Mini Orange
Mini Lime
Mini Aqua**

115V AC

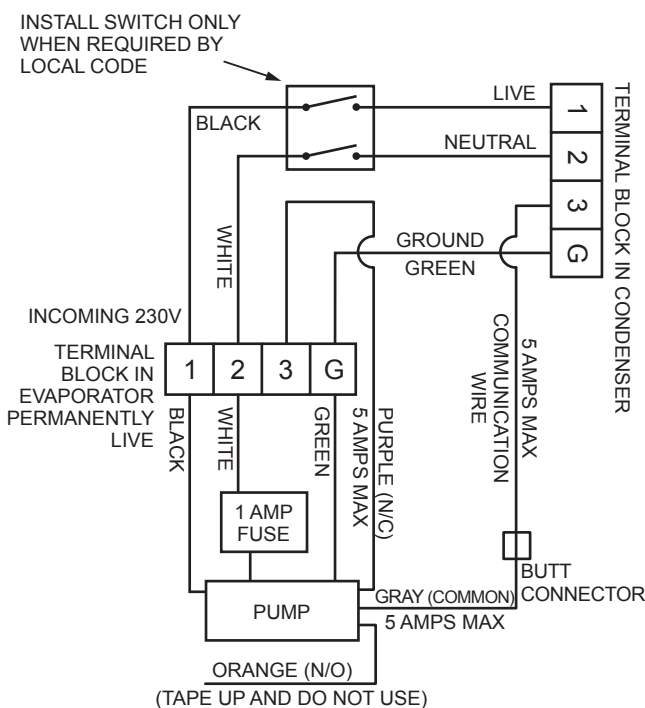

**Maxi Orange
Maxi Lime**

115V AC

